

PRESSURE TANKS

PRESSURE TANKS

- 5 models 100% stainless steel
- Many possible uses for commercial market



DESCRIPTION

PRESSURE TANKS - Stainless steel

Sta Rite pressure tanks are made of stainless steel AISI 304 in 5 models with the aim to meet all the requirements of civil and industrial systems and ensure the suitability of the product for use with food. Especially suitable for humid rooms.

HORIZONTAL: Interchangeable bromobutyl membrane with a capacity of 24 litres per membrane, with a bracket to mount the pump and a support foot. Pre-load 1.5 bar.

VERTICAL: Interchangeable bromobutyl membrane with a capacity of 8-20-24 litres. The latter also in the solution without membrane and with air supply. Pre-load 1.5 bar.

PRESSURE TANKS - Painted steel

Pressure tanks for water lifting systems, in painted steel, from 20 to 500 litres, with interchangeable membrane.

Carbon steel flange.

Preload: 1.5 bar in models 24 lt - 2.0 bar in models of 20 lt and from 50 to 500 lt

PRESSURE TANKS

Type	Code No.	Operating pressure max.	Temperature of the liquid max.	Alignment	Membrane	Feet bracket	Ca-pacity	Weight
Material:Stainless steel								
VES INOX N 8	ZA006450	8 bar	90 °C	vertical	Bromobutyl	No	8 l	2.4 kg
VES INOX N 20	ZA006460	8 bar	90 °C	vertical	Bromobutyl	No	20 l	3.3 kg
VES INOX N 24	ZA006570	8 bar	90 °C	vertical	Bromobutyl	No	24 l	5.0 kg
VES INOX N 24 H	ZA006470	8 bar	90 °C	horizontal	Bromobutyl	Yes	24 l	4.2 kg
VAA 24	ZA006610	8 bar	-	-	-	No	24 l	4.2 kg
Material:Painted steel								
VES 24 H	ZA012760	8 bar	99 °C	horizontal	Rubber for potable water	Yes	24 l	5.8 kg
VES 50 H	ZA012770	10 bar	99 °C	horizontal	Rubber for potable water	Yes	50 l	12.7 kg
VES 100 H	ZA012780	10 bar	99 °C	horizontal	Rubber for potable water	Yes	100 l	19.4 kg
VES 20 V	ZA012790	16 bar	99 °C	vertical	Rubber for potable water	No	20 l	7.5 kg
VES 50 V	ZA012800	10 bar	99 °C	vertical	Rubber for potable water	Yes	50 l	13.0 kg
VES 100 V	ZA012810	10 bar	99 °C	vertical	Rubber for potable water	Yes	100 l	19.4 kg
VES 200 V	ZA009090-CE	10 bar	99 °C	vertical	Rubber for potable water	Yes	200 l	40.4 kg
VES 300 V	ZA009100-CE	10 bar	99 °C	vertical	Rubber for potable water	Yes	300 l	53.0 kg
VES 500 V	ZA009110-CE	10 bar	99 °C	vertical	Rubber for potable water	Yes	500 l	106.5 kg

PRESSURE TANKS

PRESSURE TANKS

Fig. 1

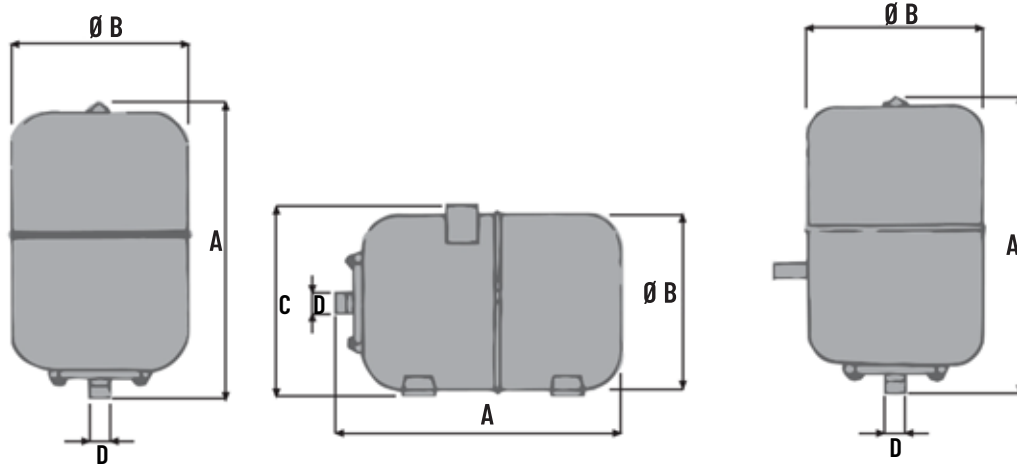
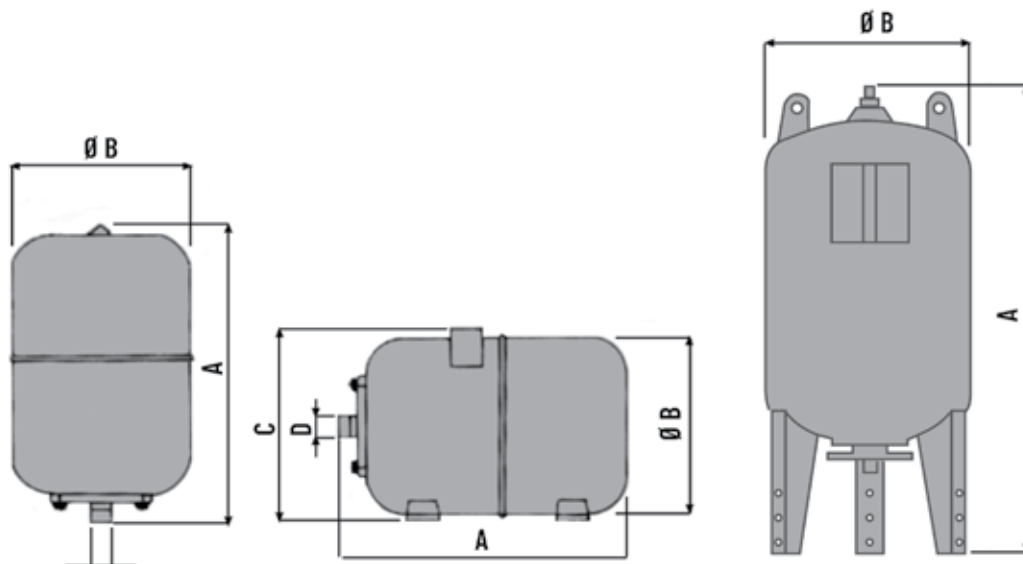

Fig. 2



PRESSURE TANKS

PRESSURE TANKS

DIMENSIONS [mm]

Type	Fig.	A	B	C	D
VES INOX N 8	1	280	226		1"
VES INOX N 20	1	390	272		1"
VES INOX N 24	1	430	272		1"
VES INOX N 24 H	1	430	272	330	1"
VAA 24	1	430	272	443	1"
VES 24 H	2	501	267	268	1" M
VES 50 H	2	589	381	408	1" M
VES 100 H	2	771	452	489	1" M
VES 20 V	2	506	254		1" M
VES 50 V	2	757	382		1" M
VES 100 V	2	914	452		1" M
VES 200 V	2	1240	550		1 1/2" M
VES 300 V	2	1386	629		1 1/2" M
VES 500 V	2	1447	791		1 1/2" M