



DOMINATOR 4 PLUS

INNOVATION



MULTI-STAGE CENTRIFUGAL PUMP
FOR FRESH WATER Ø 4"
STARITE.IT

WATER ENERGY WE PUT ENERGY INTO YOUR WATER

The Sta-Rite brand exists since 1934 and is sold in over 100 countries worldwide. In Europe, Pentair already produces a wide range of Sta-Rite swimming pool pumps and cleaners for its pool division, which have gained a reputation for quality and durability. The new European Sta-Rite line for residential water supply and water disposal will be manufactured in Italy/Pisa.

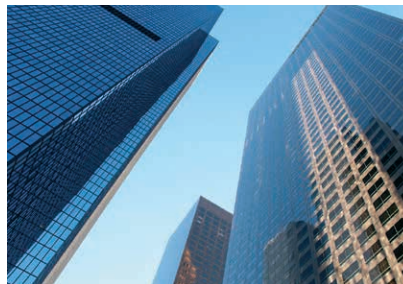

FIRE-FIGHTING AND PRESSURIZATION SYSTEMS

Vertical and horizontal centrifugal pumps. Complete systems for the transfer and pressurization of water. Fire-fighting systems.



ELECTRIC PUMPS FOR RESIDENTIAL USE

Submersible pumps, self-priming pumps, multistage centrifugal pumps and compact pumping systems for domestic water supply, irrigation and the re-utilization of harvested rainwater.



ELECTRIC DRAINAGE PUMPS

Pumps for the transfer of clear, dirty, waste water and sewage. Pumps for numerous applications (water in basins, tanks, pumping stations etc.)



ELECTRIC PUMPS FOR OPEN AND DRILLED WELLS

Submersible pumps for irrigation and pumping underground waters.

THE PISA PLANT BECOMES 100% GREEN.



Thanks to the development of a sophisticated photovoltaic system on the rooftop of the building, the Pentair Water plant in Pisa has become the first plant to produce **100% of the energy needed for its production activities.**

4100 solar panels that generate up to **1,280,000 kWh** each year have been installed on a surface area of 11,000 m².

One of the greatest advantages includes a reduction of CO₂ emissions equal to **678 ton/year**. Our customers can rest assured that products developed in the Pentair Water plant in Pisa are

completely made using renewable energy.

The remarkable results achieved by the installation of the solar panels can be seen in real time on the various screens located throughout the plant.

All activities performed at the plant in Pisa are continuously improved, aiming towards maximum energy savings and minimum environmental impact. In light of the initiatives undertaken and future plans, we can certainly say that Pentair Water is a leader in the

management of its business, characterized by:

- Maximum environmental friendliness
- Maximum energy savings
- Improved safety conditions for workers
- Maximum respect for health

DOMINATOR 4 PLUS

ELECTRIC SUBMERSIBLE MULTI-STAGE CENTRIFUGAL PUMP FOR FRESH WATER Ø 4"

Double mechanical seal, hydraulic system particularly resistant to sand corrosion, integrated check valve. DOMINATOR 4 PLUS submersible pumps with double mechanical seal are ready to use in traditional wells, water deposits, collection tanks, fresh water courses, lakes etc. Supplied with nylon suspension cord (20 m).

APPLICATIONS

- Lifting from traditional wells
- Installations in tanks in the home for pressurization systems
- Small automatic garden irrigation systems
- Gravity irrigation systems

USAGE LIMITATIONS

- Type of liquid: clean water without suspended solids or abrasive material
- Maximum liquid temperature: 40°C
- Maximum immersion below water level: 17 m

MOTOR

- Dry motor with stainless steel body cooled by pumped liquid
- Protection rating IP 68
- Insulation class F
- Single phase power supply with permanently activated capacitor
- Thermal cutout protection incorporated in motor winding
- Fully insulated cable connection chamber
- Self-lubricating ball bearings
- Rotation speed 2850 rpm
- Suitable for continuous duty

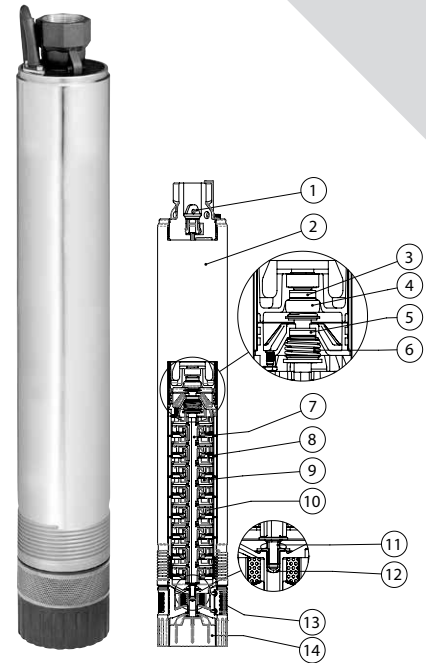
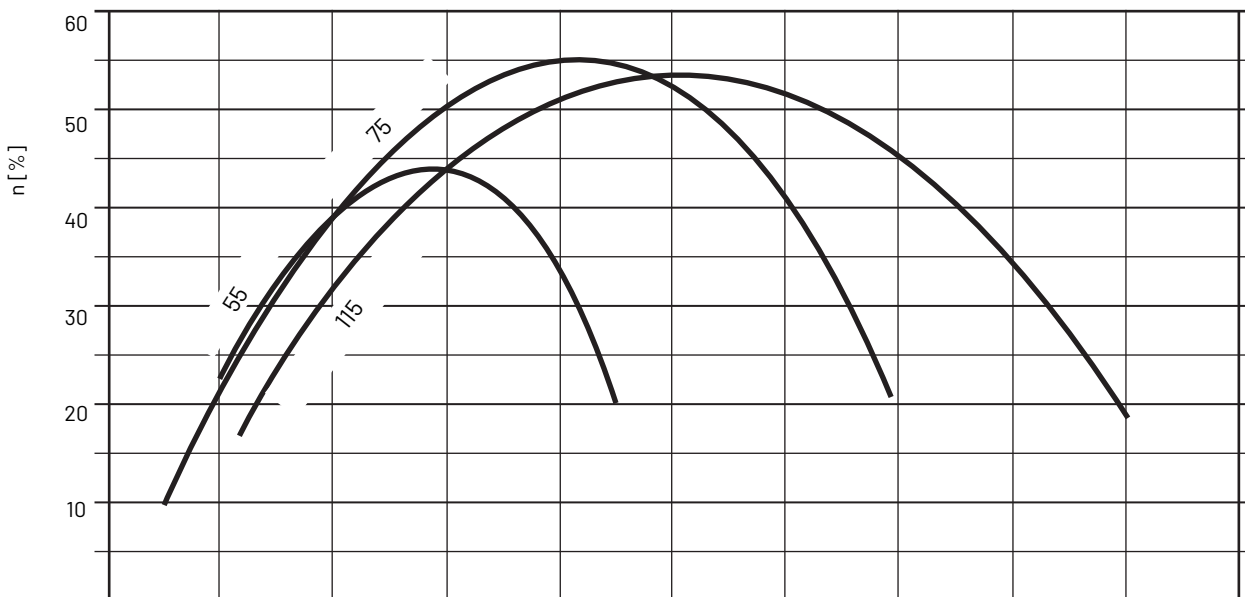
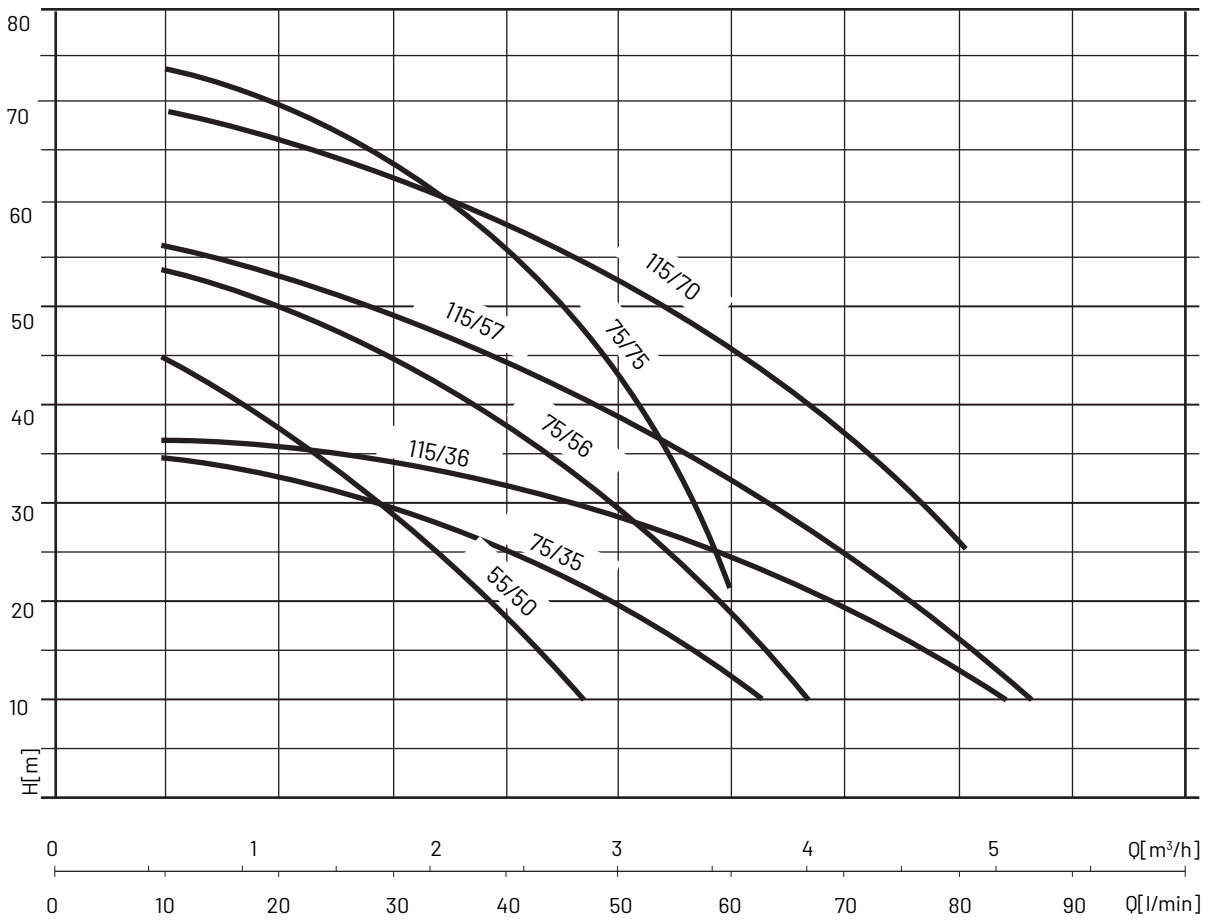

TABLE OF MATERIALS

N.	COMPONENTS	MATERIALS
1	CHECK VALVE	Thermoplastic with NBR o-ring - integrated
2	PUMP BODY	Stainless steel Europe: EN10088-1 X 5 CrNi 1810 (1.4301) Usa: AISI 304
3	MECHANICAL SEAL - STATIONARY PART OIL CHAMBER	Aluminium oxide / NBR
4	MECHANICAL SEAL - ROTARY PART OIL CHAMBER	Stainless steel Europe: EN10088-1 X 5 CrNi 1810 (1.4301) Usa: AISI 304 / NBR / Carbon graphite resin impregnated
5	MECHANICAL SEAL - STATIONARY PART	Aluminium oxide / NBR
6	MECHANICAL SEAL - ROTARY PART	Stainless steel Europe: EN10088-1 X 2 CrNiMo 17-12-2 (1.4404) USA: AISI 316 / NBR / Carbon graphite
7	MOTOR SHAFT	Wet side - Europe: EN10088-1 X 8 CrNiS 18-9 (1.4305) USA: AISI 303/ Motor side - carbon steel
8	DIFFUSER CAP	Polycarbonate with stainless steel wear insert Europe: EN10088-1 X 5 CrNi 1810 Usa: AISI 304 (1.4301)
9	DIFFUSER	Polycarbonate with ceramic wear insert
10	IMPELLER	Acetal resin
11	BUSHING	Stainless steel Europe: EN10088-1 X 8 CrNiS 18-9 (1.4305) USA: AISI 303 with ceramic coating
12	BEARING	Self lubricating Nylatron®
13	SUCTION FILTER	Stainless steel Europe: EN10088-1 X 6 Cr 17 (1.4016) USA: AISI 430
14	BASE	PPO - Noryl™ GFN 2
-	Power cable	Type H07 RN-F - length 20 m

Thrust ring inserted in each stage

HYDRAULIC PERFORMANCE



MEI $\geq 0,4$ - MEI reference ≥ 0.70 - The reference efficiency information is available on the website: www.europump.org/efficiencycharts

PERFORMANCE TABLE

MODEL	Motor output (P2)		Power motor (P1)		VOLTAGE (V)	In (A)	µF	STAGES	Ø	Q						
	HP	kW	HP	kW						l/min	0	20	40	60	80	
										m ³ /h	0	1.2	2.4	3.6	4.8	
DOMINATOR 4 PLUS 55/50 M	0.75	0.56	1.1	0.8	1~230	3.8	16	6		50	38.7	17				
DOMINATOR 4 PLUS 75/35 M	0.50	0.35	0.80	0.60	1~230	3	12.5	5		35	33	26	11			
DOMINATOR 4 PLUS 75/56 M	0.80	0.60	1	0.75	1~230	3.3	16	8	m.c.a./m.w.c.	56	48.9	38.1	19			
DOMINATOR 4 PLUS 75/75 M	0.95	0.7	1.5	1.1	1~230	5	20	11		75	70	53	21.6			
DOMINATOR 4 PLUS 115/36 M	0.55	0.40	1	0.75	1~230	3.5	12.5	5		36	35	32	25	13		
DOMINATOR 4 PLUS 115/57 M	1	0.8	1.50	1.10	1~230	5	16	8		57	52	44.4	31.5	16.6		
DOMINATOR 4 PLUS 115/70 M	1.1	0.8	1.8	1.3	1~230	6	20	10		70	65	59	45.4	27		

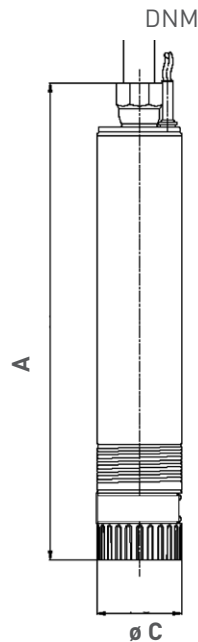

OVERALL DIMENSIONS AND WEIGHTS

MODEL	Dimensions (mm)				Weight (kg)
	A	Ø C	Free clearance	DNM	
DOMINATOR 4 PLUS 55/50 M	549	98	2 mm	1"1/4	10.4
DOMINATOR 4 PLUS 75/35 M	560	98	2 mm	1"1/4	10.2
DOMINATOR 4 PLUS 75/56 M	643	98	2 mm	1"1/4	10.8
DOMINATOR 4 PLUS 75/75 M	760	98	2 mm	1"1/4	12.5
DOMINATOR 4 PLUS 115/36 M	560	98	2 mm	1"1/4	10.2
DOMINATOR 4 PLUS 115/57 M	643	98	2 mm	1"1/4	10.8
DOMINATOR 4 PLUS 115/70 M	732	98	2 mm	1"1/4	12.5

Technical data subject to change without notice. PENTAIR WATER ITALY reserves the right to carry out modifications to its products at any time without having to provide prior notice.



Pentair Water Italy | Via Masaccio | 13 56010 LUGNANO (PI) | ITALY | starite.it

Pentair Sta-Rite is a trademark, or registered trademark of Pentair or its subsidiaries in the United States and/or other countries.

Because we are continuously improving our products and services, Pentair reserves the right to change specifications without prior notice.

Pentair is an equal opportunity employer.

NV260A700 ED. IT - Rev.0 - 01/18 © 2018 Pentair Water Italy. All Rights Reserved.